

UNCLASSIFIED



Australian Government

Department of Defence
Defence Science and
Technology Organisation

Performance Evaluation of Airborne Mission Systems in the Acquisition Process

Kiril Uzunov
Air Operations Division

DGTA Software Symposium
23-24 August 2011, RAAF Laverton

DSTO

UNCLASSIFIED

Outline

- Motivation
- Methods and tools for performance estimation
- Results and limitations



Mission System trends

- Multi-mission aircraft
 - Increasingly integrated and automated functionality
 - Increasing size, **complexity** and criticality of software intensive systems
 - Increased sensor capability
 - Long lifetime of a platform
 - New technologies – COTS and reuse
-
- Emphasis on understanding real performance

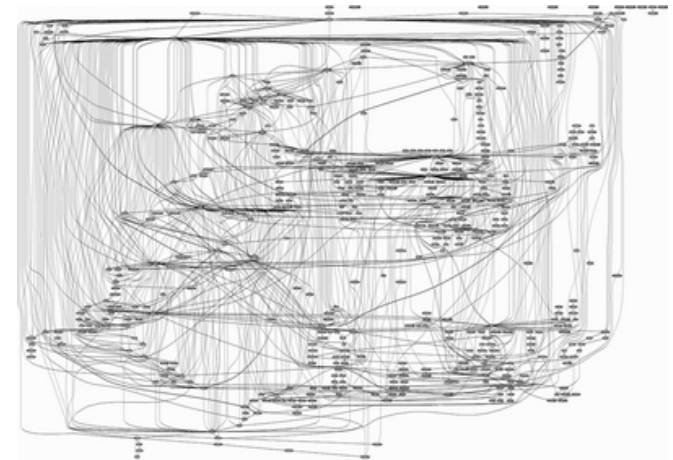
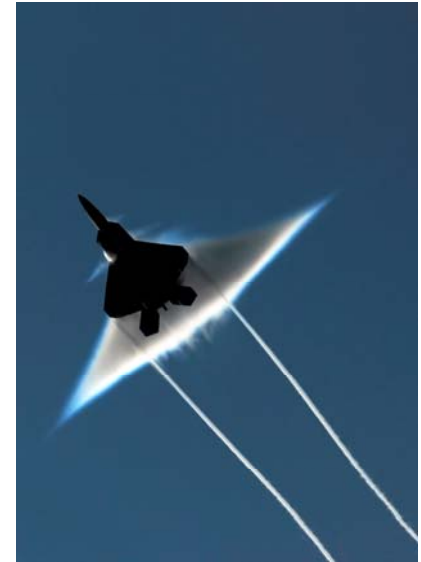

UNCLASSIFIED

DSTO

Acquirer's perspective

- No or restricted access to code and development environment
- Identify processes and look for adherence
- Observe issues crop up and watch for solutions and recovery
- Risk mitigation activities – research in performance estimation, modeling and benchmarking, prototype development



UNCLASSIFIED

DSTO

Product uncertainty

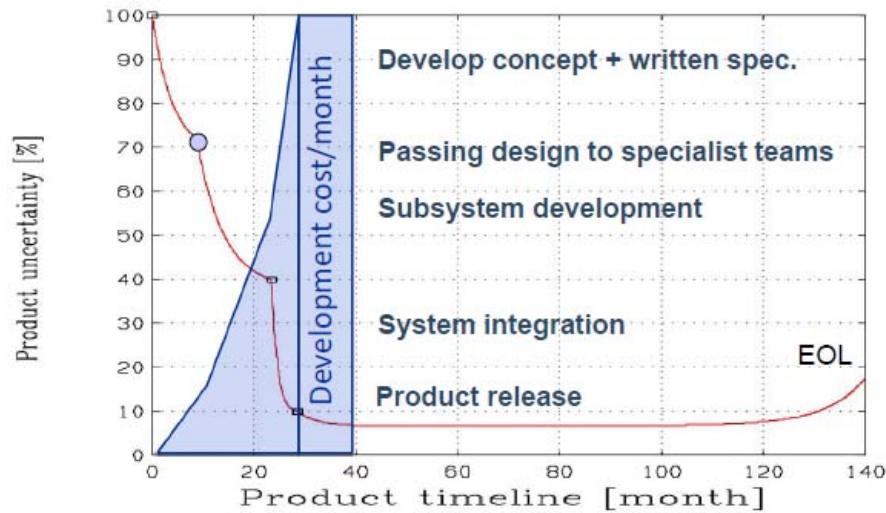
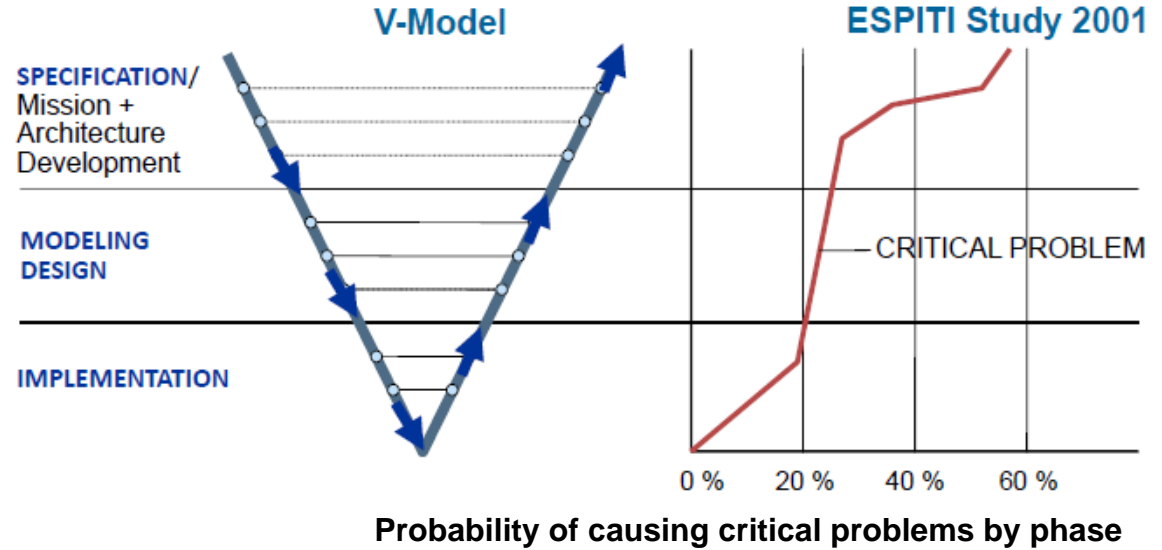

UNCLASSIFIED

DSTO

Mission System development: time analysis

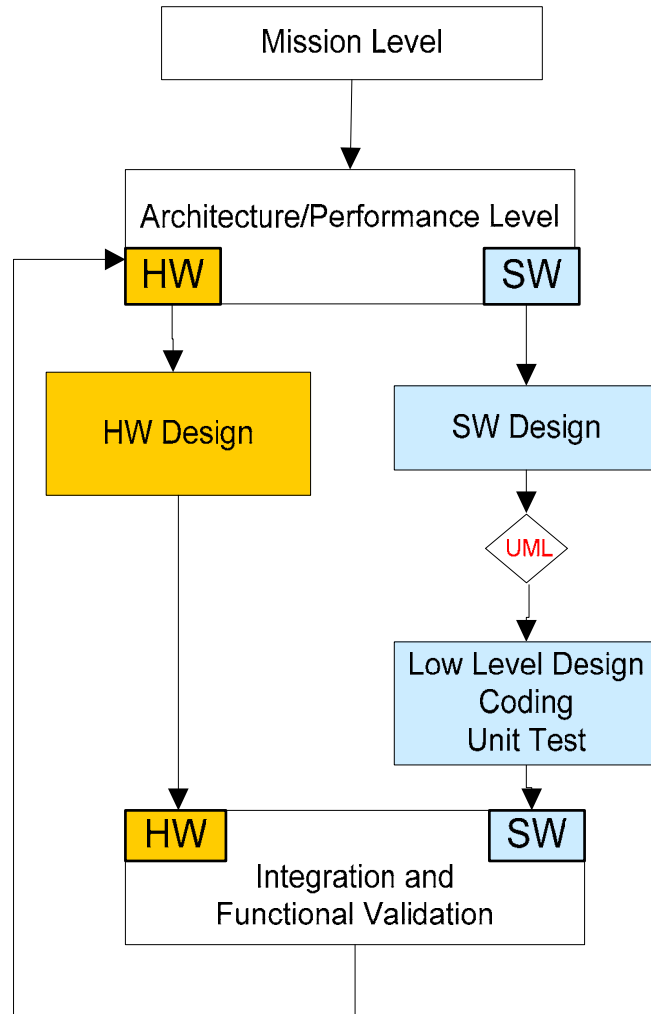

- Early architecture exploration
 - Selection of network topology, processors
 - Mapping of applications to processing nodes
 - OS/scheduler configuration
- Later stages
 - Verification
 - Safety and certification
 - Calculating reserve capacity for growth

UNCLASSIFIED

DSTO

Performance evaluation techniques

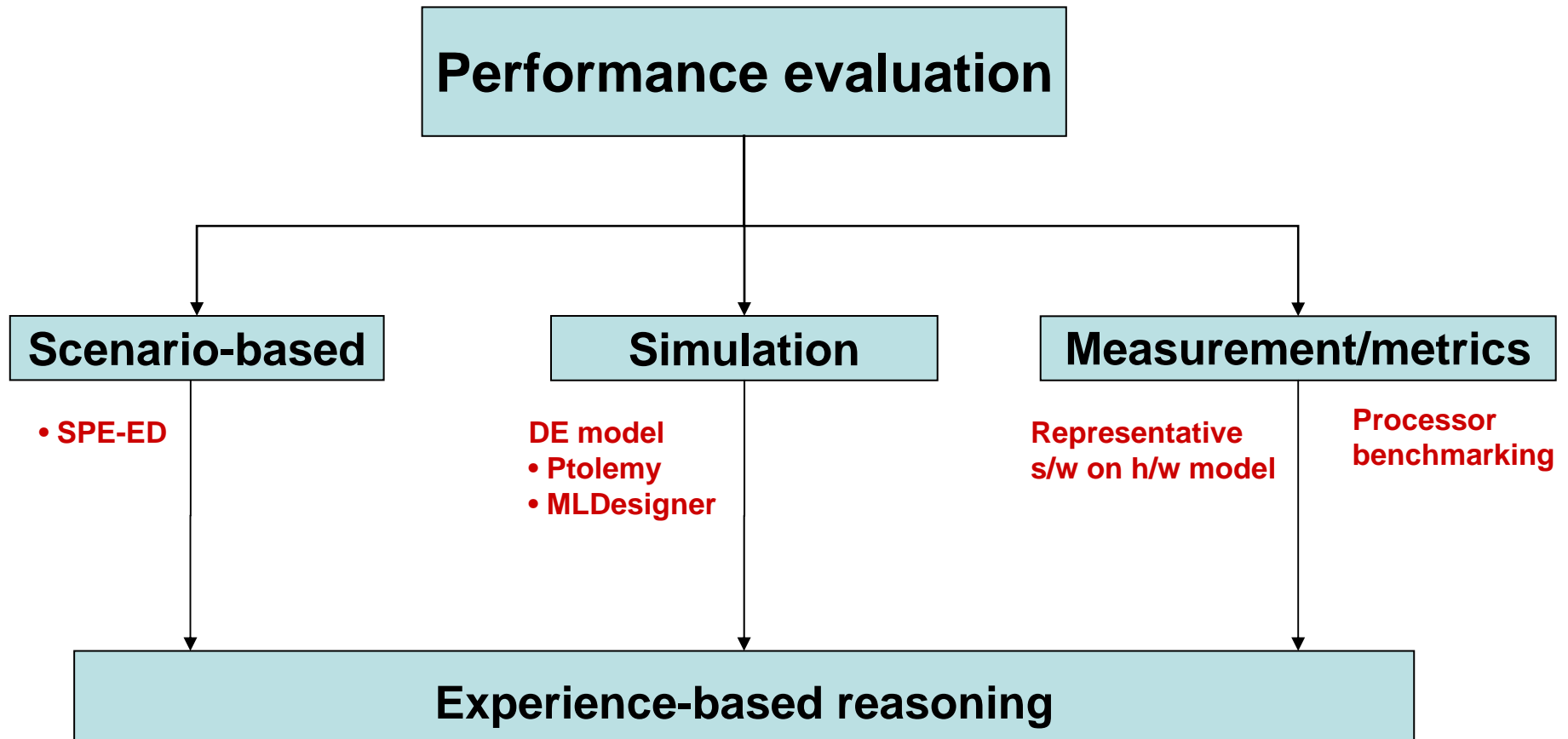

UNCLASSIFIED

DSTO

MS performance modelling flow

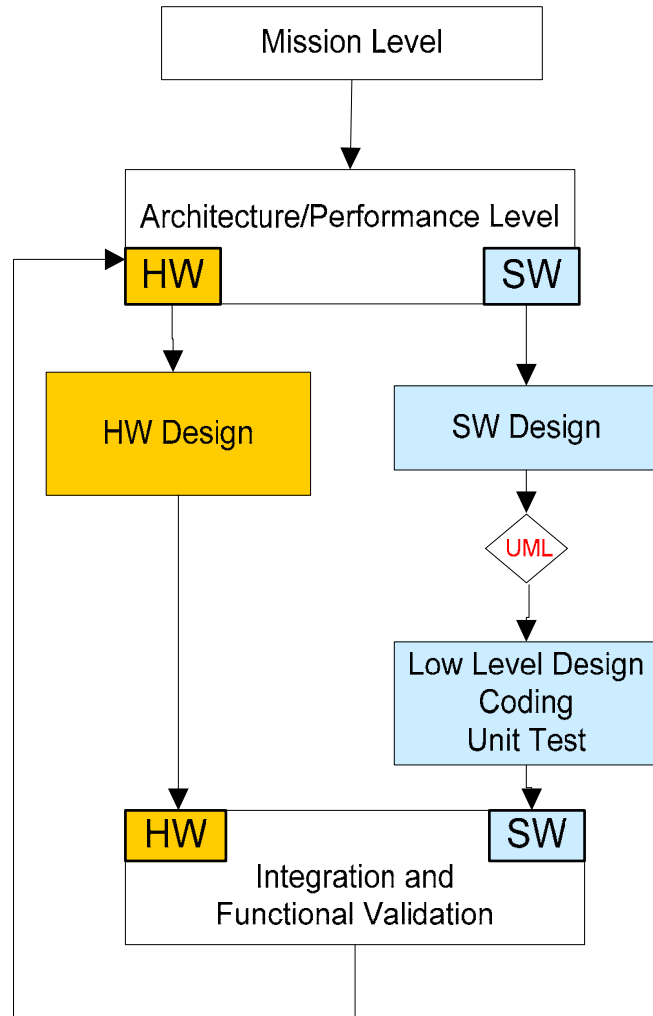

UNCLASSIFIED

DSTO

MS performance modelling flow

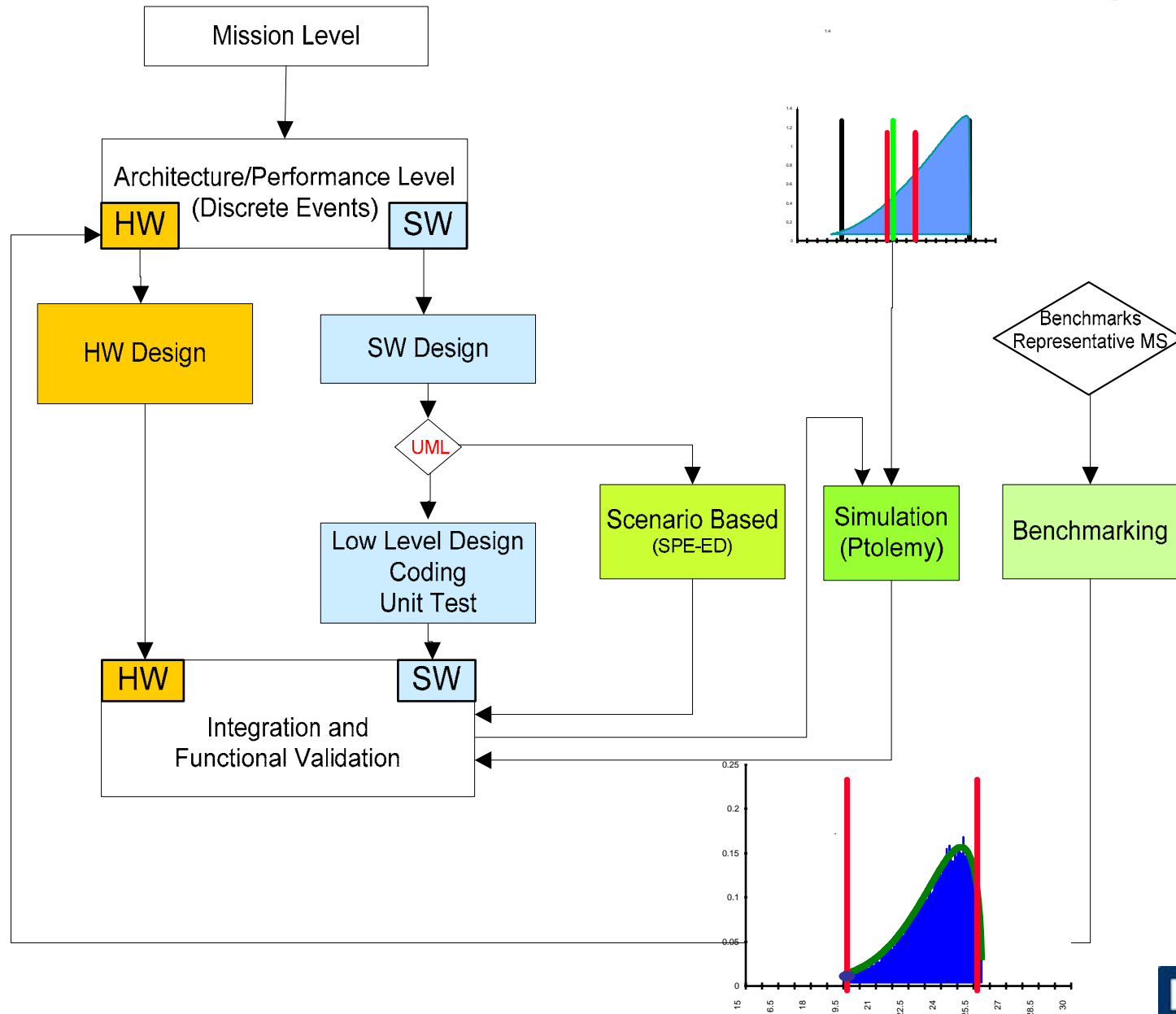

UNCLASSIFIED



Scenario based

Performance estimation using SPE-ED

1a Scope and Scenario



1b UML model

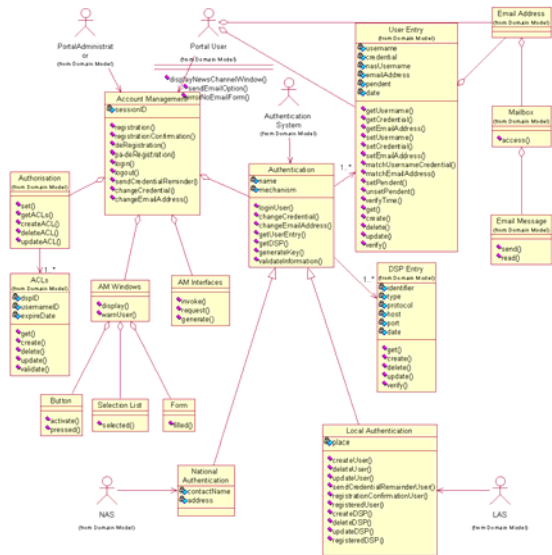

2 UML Sequence diagram

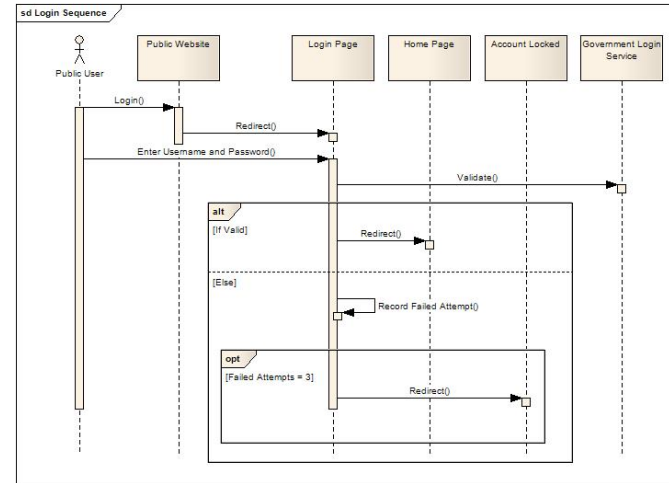

3 Execution graph

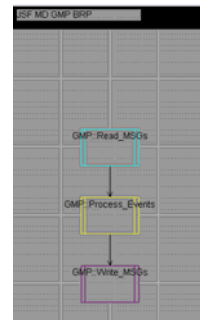

4 SPE-ED model

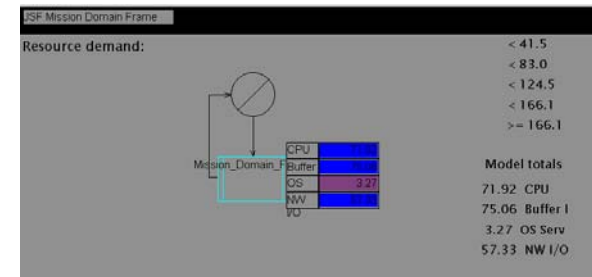

UNCLASSIFIED



WCET based calculator

Timing validation

Needs WCET for each task

- Code level
 - end-to-end measurement
 - static analysis
 - hybrid analysis

- System level
 - end-to-end measurement
 - schedulability analysis (timing validation)



Simulation based



Ptolemy based DE model

Ptolemy terminology

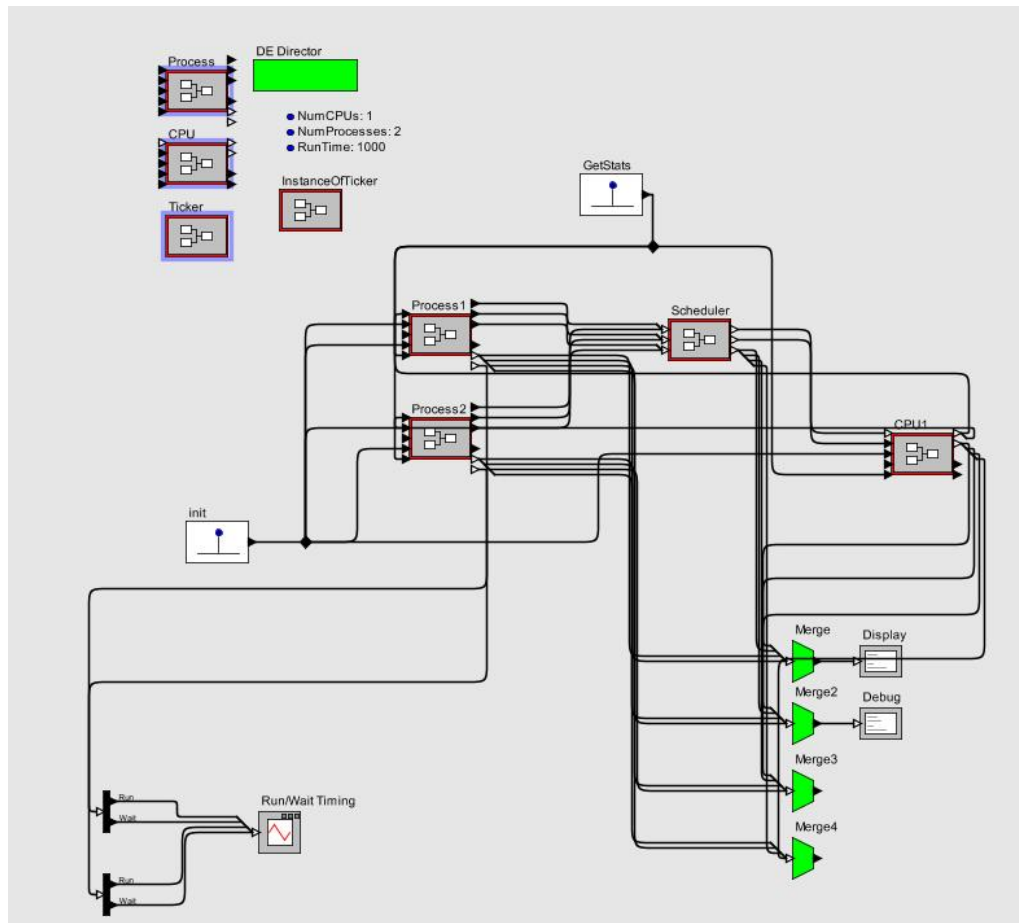

- Actors
 - Process actor
 - CPU actor
 - Scheduler
- Ports
- Events
- Parameters

UNCLASSIFIED

DSTO

Ptolemy displays

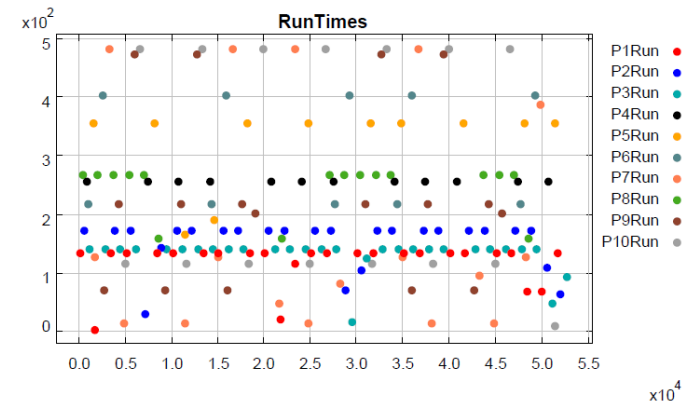
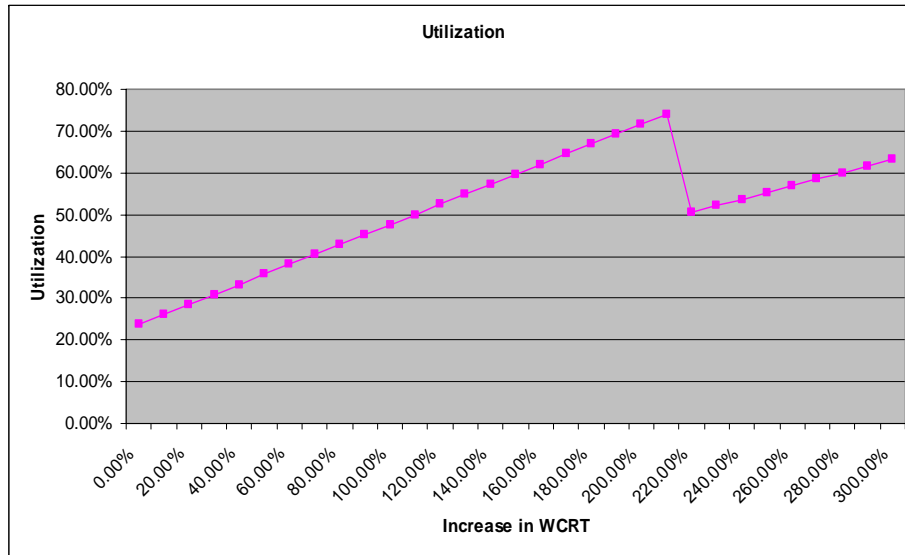

UNCLASSIFIED



benchmarking

Benchmarking/measurement

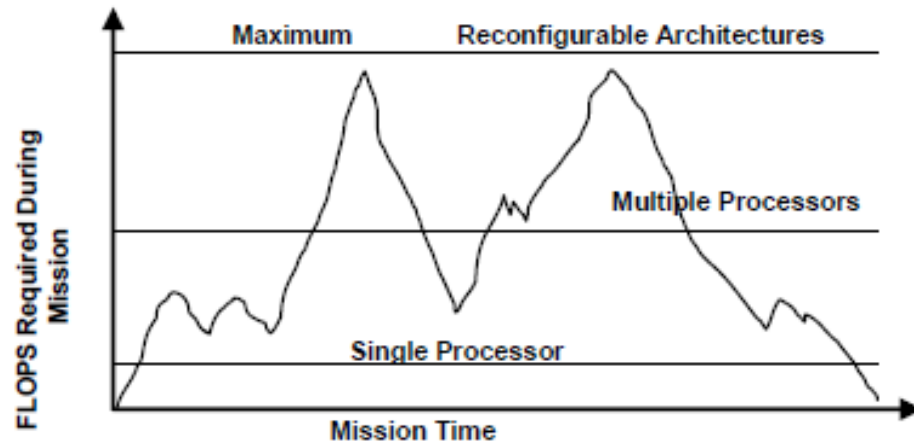

- paper-based analysis
- benchmarking phase
- insertion scenarios



UNCLASSIFIED

DSTO

benchmarking

Representative Mission System

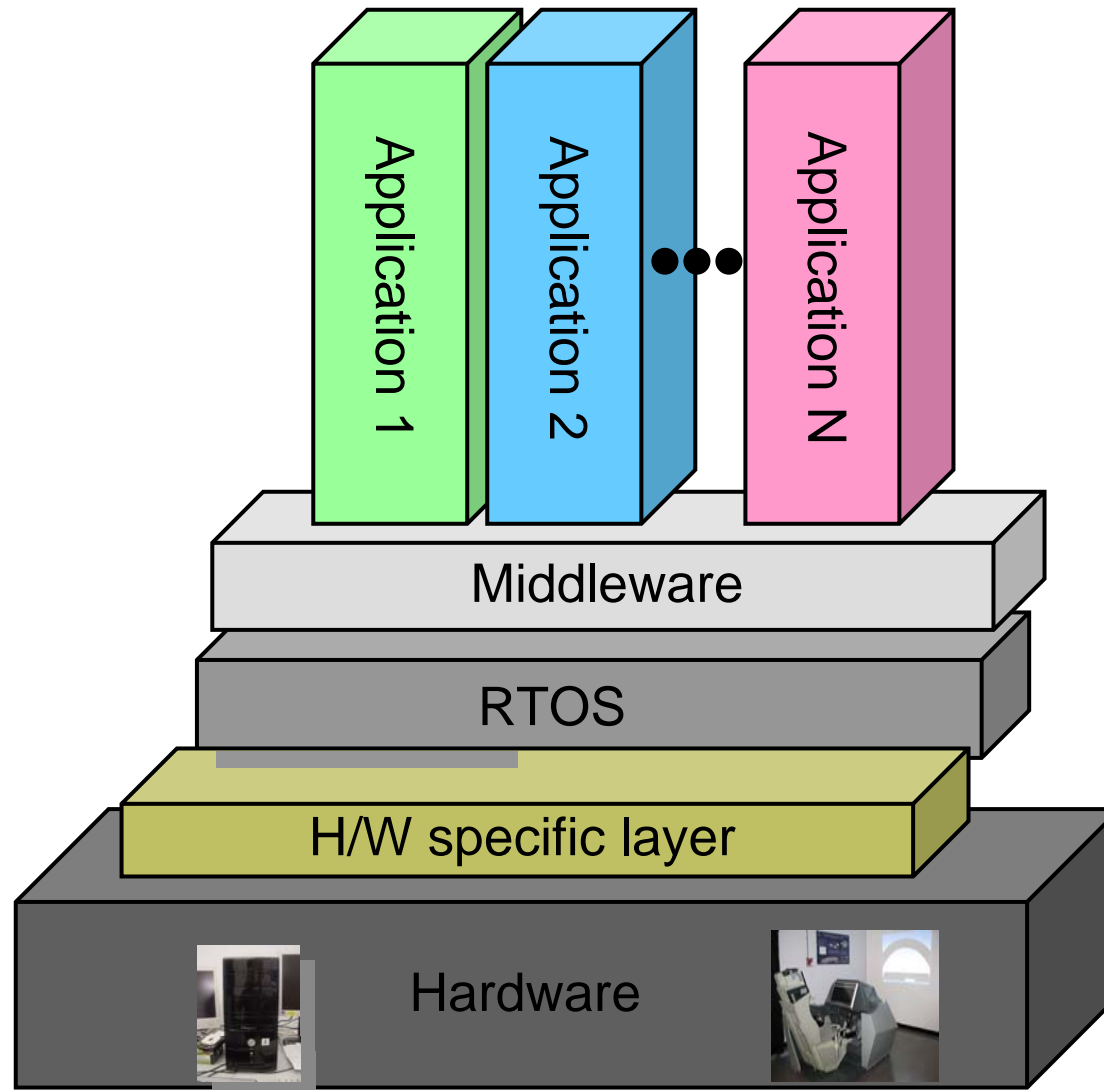

UNCLASSIFIED

DSTO

To conclude

- Acquirer prospective – risk assessment and mitigation
- Three approaches to performance evaluation based on limited information
- Using different approaches helps with validating the results
- Although the fidelity of these models is limited, they are a useful tool to monitor the risks and rigour of development.



Acknowledgments:

Ryan Hales – SPE-ED modelling

Simon Lemmo – benchmarking

Callum Baillie – Ptolemy DE model

UNCLASSIFIED

DSTO



UNCLASSIFIED

DSTO